

TROUBLESHOOTING

Always disconnect the pump from the power supply before handling.

If the pump, optional water feature fail to operate:

- Check to make sure the power cord is plugged in and the receptacle has stable power supply running to it.
- Check to ensure water level is above sensor.
- Check the front cover of pump for dirt and obstructions.
- Check the tubing for kinks or obstructions.
- Check if water feature outlet or tubing is clean and clear.

If water flow has not returned:

- Remove front cover and impeller cover to access rotor area.
- Rotate the rotor to ensure it is not broken or jammed.
- Remove the rotor to check it is free from any debris.
- Rinse the cover and re-assemble.

LIMITED WARRANTY

These components are warranted to the original user against defective materials and workmanship for a period of 12 months. Our limited warranty does not cover any costs associated with the installation or removal of products subject to warranty claims or the cost of return. The warranty will commence from the date of purchase. Replacement liability is limited to any part or parts of the unit which have failed due to defective material or workmanship. Proof of purchase is required for all claims against the limited warranty. This warranty does not extend to damage of the product or part resulting from accident, misuse, alteration, neglect, abuse, improper installation or normal wear and tear to the product(s). This limited warranty extends only to the original user of the product.

For more information please visit our web site:

www.angelodecor.com

PLEASE DO NOT RETURN THIS UNIT TO THE STORE.

To **contact us** regarding this unit, your options include:

Email: **customersupport@angelodecor.com**

Phone: (780) 453 - 6646 | Fax: (780) 453- 6620

Angelo Décor International Inc. | 13619 – 149th Street NW | Edmonton, AB | T5L 2T3



Safe Stop™ Fountain Pump

AD40169 / AD40172 / AD40224 / AD40226 / AD40321

THANK YOU FOR BUYING AN ANGELO DECOR PRODUCT.

PACKAGE CONTENTS

Output(s)
Flow Control Cover
Fountain Pump Motor
Power Cord
Rear Cover

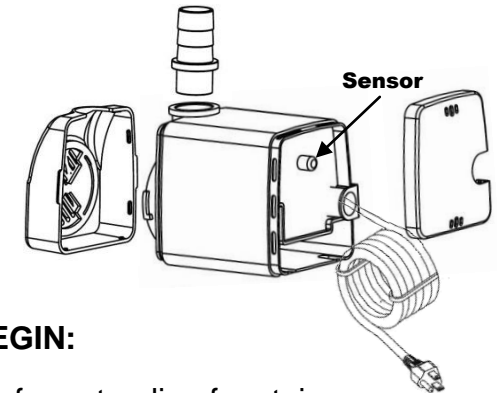

IMPORTANT - BEFORE YOU BEGIN:

This pump is **intended for use** in free-standing fountains and water features in “**clean water operations**”.

It is not compatible with salt water.

It should be **installed properly** inside features based on this instruction manual to **ensure this feature works as intended**.

The **Safe Stop™ feature** uses a **sensor** designed to detect low water levels, **protecting your pump from running dry**.

Water level must be at or above the level of the sensor for the pump to resume operation. A few seconds delay after adding water back to adequate level is normal.

QUESTIONS?

PLEASE DO NOT RETURN THE ITEM TO THE STORE.

Please visit our website **www.angelodecor.com** for more information and **how-to videos** on how to assemble and **properly use your product**.

WARNING: SAFETY AND ELECTRICAL CONNECTIONS

The pump is supplied with 3 core electrical cable, permanently connected and sealed to the motor. **The cable cannot be replaced.** Pump should be returned if found immediately, or discarded if cord is damaged through use, neglect, or improper handling.

- Use **only** a ground fault circuit interrupter (**GFCI**) receptacle.
- **Do not connect to any voltage other than that stated on the pump.** Wrong power ratings supply will cause immediate damage.
- Always unplug or disconnect from power supply before putting hands in the water, while equipment is being handled in any way.
- Do not use the cable to lift the pump as this may cause damage.
- Keep cord away from high temperatures or any element that may cause physical damage.

PLACEMENT OF PUMP IN WATER FEATURE

The pump must always be placed in a “standing” position. Pump should never be allowed to sit on its side, as this will disable the Safe Stop™ feature.

A slight **forward tilt** will help the **intake at the front** of the pump to **remain fully submersed**, reducing air pockets in the water line.

Placing a small stone under the back of the pump, or securing the power cord to affect this “tilt” is highly recommended.

A “loop” in the connected tubing (shown right) will also help the Safe Stop™ feature to **operate at peak efficiency.**

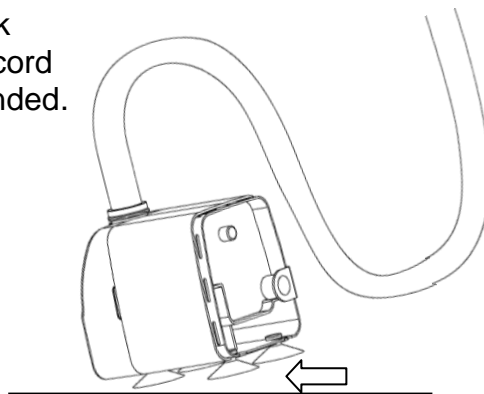

CARE AND MAINTENANCE

Before attempting any adjustments, always **disconnect the pump** from the power supply and remove from pond.

- The **pump works best**, and lasts longest, if it remains **fully submerged.**
- **Clean components** when a drop in performance is noted or **exterior, especially input is visibly soiled.**
- Disassemble the unit regularly to **clean mineral deposits** and **build-up of debris inside the Rotor and magnet.**

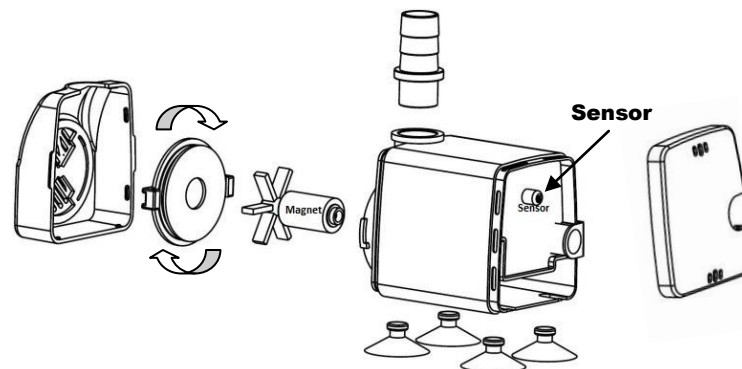

- Use a cloth or **soft brush, white vinegar** or mild soap when cleaning. Monitor the sensor for any buildup, careful not to damage or puncture it when cleaning gently.
- **Do not pump heated liquids or water that is above 40°C.**
- Do not operate this pump **below 4°C**, as **FREEZING DAMAGE MAY OCCUR.**
- If temperature is likely to fall **below 4°C** remove the pump **from the pond**, ensure all water is removed from the pump and the unit is **completely dry and stored** in a frost-free place.